

Electromagnetic Flowmeters



Insertion Sensors MUT 2700

DS180-1-ENG 

Sensor MUT 2700

EUROMAG INTERNATIONAL Insertion flowmeters represent the best answer when low costs and good performance are needed. The MUT2700 sensors are suitable for wide pipes, and can be installed without interrupting the flow. They are made of a probe which has to be inserted into the tube for 1/8 of its internal diameter. The nominal working pressure is 16 bar. The sensor is installed through a threaded muff to be connected to its ball valve, once it is welded to the pipe.

1. Body

MUT2700 sensors are made of AISI 304 stainless steel supplied together with a bronze ball valve. In the separate version they have an IP68 protection degree for immersion in 1.5 meters.

The junction box placed on top of the sensor, has two glands for the cables connection. The MUT2700 models are available with several lengths, to fit various pipe diameters (Table 1).

2. Electrodes

The electrodes are in AISI 316 L stainless steel.

3. Maximum liquid temperature

In the separate version, the maximum liquid temperature is +180°C. While in the compact version, it depends on the environmental temperature since the converter may not work properly over 60°C.

4. Coupling and connection to converter

MUT2700 sensors are compatible with all EUROMAG INTERNATIONAL converters. In the separate version the sensor is connected to the converter through two cables, whose length depends on the liquid conductivity and must not exceed 100 metres (see Fig. 1). In the compact version, the converter is mounted directly on the junction box.

5. Assembly

The MUT2700 sensors are suitable for installations under pressure; so there is no need to interrupt the flow in the pipe. For the installation, just weld the 2" threaded muff to the pipe, connect the ball valve and then insert the sensor (threaded muff and ball valve are also provided with the sensor). The probe has to be inserted into the tube for 1/8 of its internal diameter. The screw system guarantees a correct insertion and fix the sensor at the correct length and position, even when the nominal working pressure reaches 16 bar. When installing the sensor, the minimum distances of 10 diameters upstream and 5 diameters downstream must be respected, making a 90° angle with the pipe as per Fig. 2.

6. Calibration and maximum error

MUT2700 sensors belong to the reference Group B1 (ISO 11631). Each sensor is calibrated on our hydraulic bench according to the reference weighing system SIT. Upon a correct installation the measuring accuracy is 3% of the read value, with a flow velocity higher than 0.3 m/s.

7. Reference standards

EUROMAG INTERNATIONAL magnetic meters are marked CE and are manufactured according to the following standards:

- * CEI EN 61010-1
- * UNI EN ISO 6817
- * EN 14154
- * EN 50081 - 1
- * EN 50082 - 1

Maximum length of cables according to the liquid conductivity

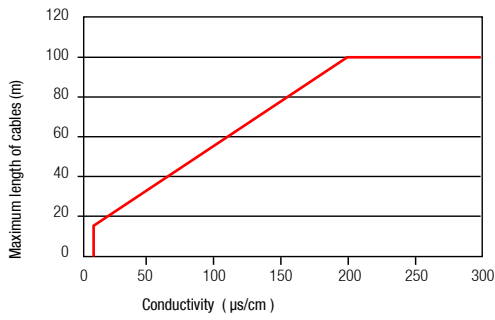

fig. 1

Sensor MUT2700 dimensions

Size	3	5	7
Max. Diameter Permitted [mm]	1000	2000	3000
Length Ls [1]	922	1192	1462

[1] The dimensions are referred to the base of the derivation box, in "fully extracted" position. table 1

Sensors MUT2700 General characteristics

Size range	Minimum pipe diameter	80 mm		
	Maximum pipe diameter	3000 mm		
Available electrodes	AISI 316L			
Body material	AISI 304 Stainless Steel			
Head of sensor	PTFE			
Standard Operating Pressure	16 bar (25 bar optional)			
Liquid temperature	40°C ÷ +180°C			
Protection Degree	IP68 for immersion in 1,5m (IEC 529)			
Converters compatibility	MC 106	MC 108	MC 308	MC 308 C
Parts in contact with liquid	Head of sensor	Electrodes		End part of pipe
	PTFE	[*]		AISI 304 Stainless Steel
Electric connections	Cable glands PG 11 + Terminal block + Sealing resin			

table 2

Installation

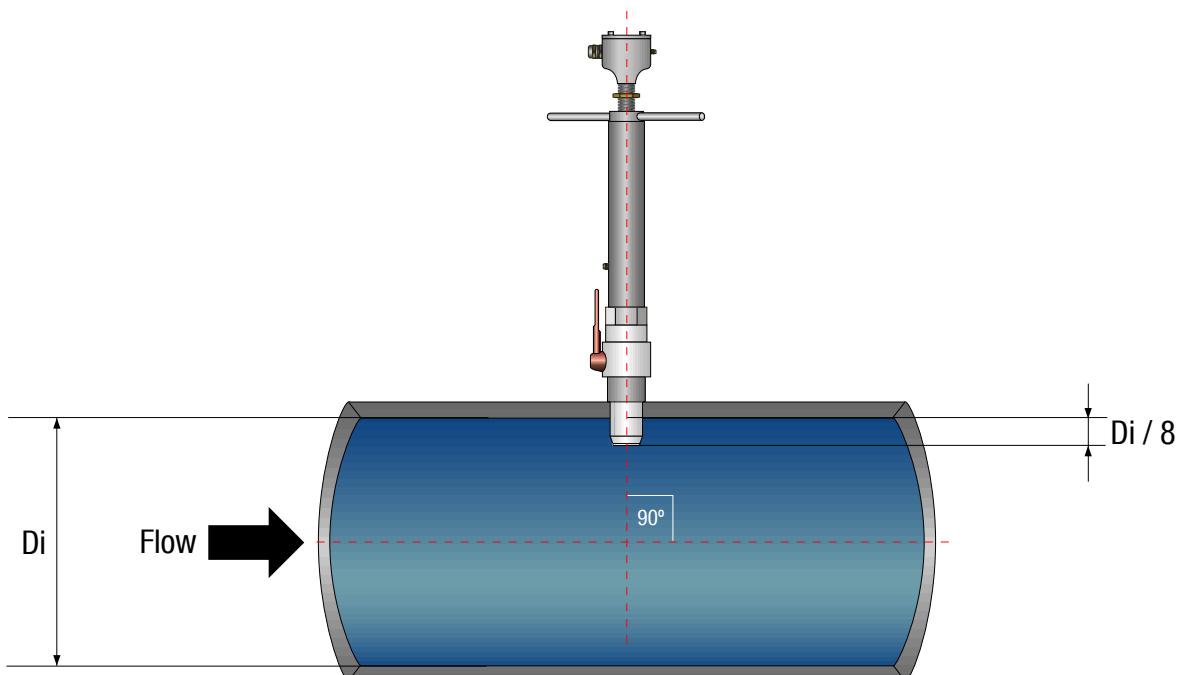

fig. 2

Overall dimensions - Work position

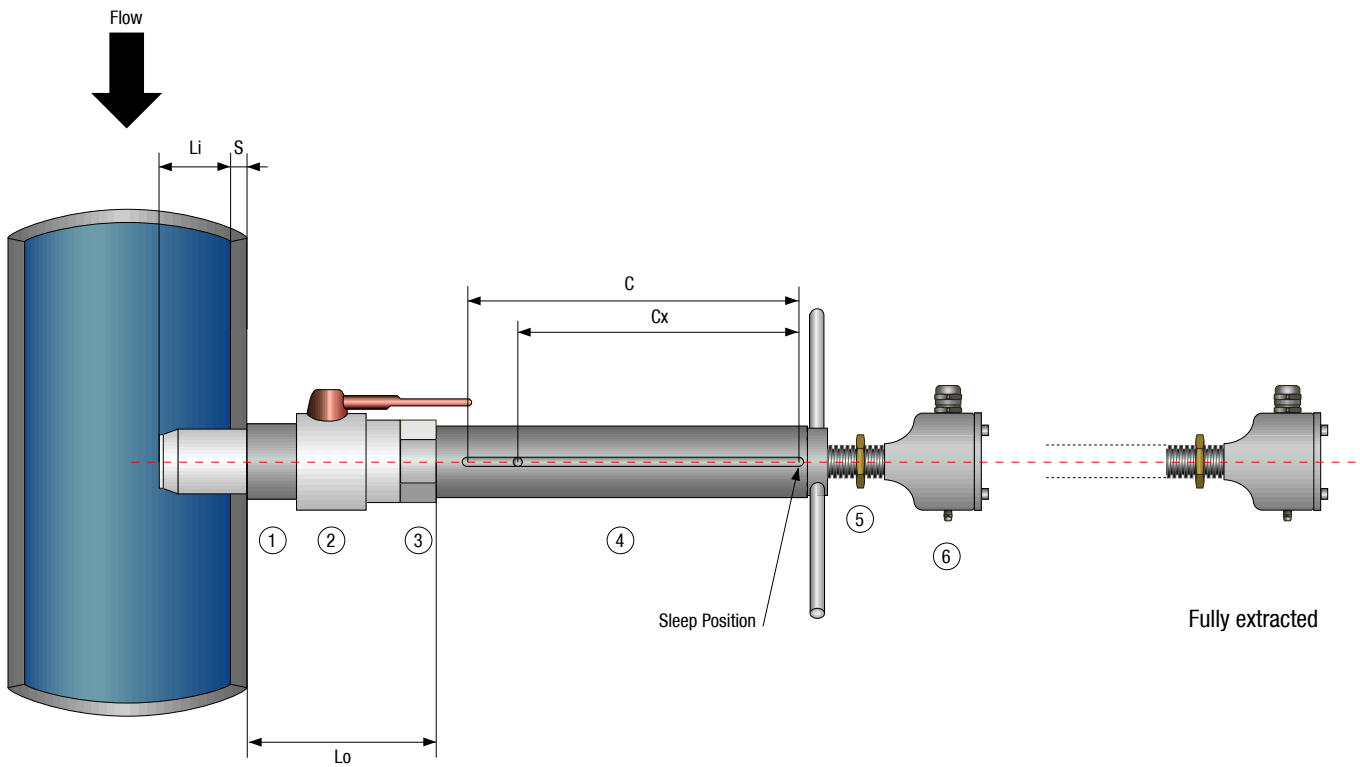

fig. 3

References

①	COUPLING 2" Gas - AISI 304
②	BALL VALVE M+F 2" Gas FB - Bronze
③	ADAPTOR 2" Gas - Chrome Brass
④	FLOWMETER MUT2700
⑤	SECURITY DIE - Bronze
⑥	DERIVATION BOX
Lo	Distance between pipe's external side and ball valve's superior face (with the installed adaptor)
Li	Insertion length = $(De - 2S) / 8$
C	Maximun travel of sensor
Cx	Operating travel = $Li + S + Lo - 44$

DN	SIZE	Lo*	Li max	C
≤ 1000	3	* To be measured after installation	125	300
≤ 2000	5		250	435
≤ 3000	7		375	570

The data shown in this catalogue are subject to modification without prior notice