

# GSI-2570 Float Gauge

## Automatic Tank Gauge

The GSI-2570 is a float actuated instrument that provides continuous and reliable liquid level measurement. Specifically designed to reduce maintenance and improve reliability, it eliminates many operational and maintenance problems found within other float actuated gauges.

The GSI-2570 is a low pressure gauge, suitable for installation on tanks with working pressure up to 15 psig. The GSI-2570 can be purchased as a gauge head to upgrade older or broken gauges and purchased as a gauge kit for new tank installations. GSI offers the 2570 in a variety of gauge and kit options. GSI gauge kits are engineered to fit the tank application, i.e., product content, service requirements, and physical tank construction.

Engineered improvements of the GSI-2570 Automatic Tank Gauge include:

- The Negator Cassette (OPTIONAL). The GSI-NC Negator Cassette is an internally installed, fully enclosed Negator motor spring that:
  - 1) Improves accuracy by eliminating debris from falling into the Negator motor spring and weakening it.
  - 2) Cuts maintenance costs by reducing Negator motor spring replacement time to minutes instead of hours.
  - 3) Improves safety by eliminating the danger of being cut by the Negator motor spring. (See product Bulletin 2590 for additional Negator Cassette Information).
- The GSI-DCA Dual Calibration Assembly (OPTIONAL). The GSI-DCA is an internally installed mechanical assembly that allows simultaneous calibration of both the mechanical gauge head and transmitter. It thereby reduces time spent on system



### GSI-2570 features include:

- Accuracy 1/8" or 3 mm
- Aluminum Gauge Head with Stainless Steel wetted parts, other materials optional
- Direct Innage or Outage readings; English-fractional, English-decimal, or Metric counter assemblies
- Optional Negator Cassette "NC" (motor spring cartridge)
- Standard, Extra heavy, or Long (Negator) motor springs available
- Optional Dual Calibration Assembly "DCA" (Testing & Calibration of both the gauge and transmitter / limit switches at the same time)
- Gauge head and counter housing suitable for oil filling
- Backplate cap for mounting of a digital transmitter, analog transmitter, or limit switch.
- Gauge kits suitable for various product services or physical tank construction
- Floats available for various guide wire centers, stilling wells, and product services
- QA - Hand checked and tested before delivery

### Gauging Systems Inc. (GSI™)

910 Industrial Blvd., Suite A • Sugar Land, Texas 77478

Phone: (281) 980-3999 • Fax: (281) 980-6929 • E-mail: GSIHouTx@msn.com

calibration. (See Bulletin 2595 for additional information on the GSI-DCA)

- The GSI-2570 counter assembly is hole drilled for minimum movement. No slotted mounting holes, the GSI-2570 counter assembly requires little or no adjustment. It thereby is less likely to hangup than some other gauge models.
- Gauge Check Handle. The GSI-2570 comes complete with an easy to grip gauge check handle made of cast Aluminum, not plastic.

The gauge check handle when turned ratchets the tape sheave storage assembly, thus picking up 1"- 2" of tape and the float. This allows the testing of the Negator motor's strength. It also is used for checking gauge calibration, plumbing of the roof weight, or freeing hung-up gauges. Some other gauge models do not support gauge checkers or the checkers merely bump the tape. A gauge check handle is the only safe way to test the Negator motor spring's strength, i.e., a weak Negator motor spring will affect the level gauge accuracy.

- The GSI-2570 uses a hair pin spring that is wrapped around the rivet to the checker pawl. The spring stays in place when the gauge check handle is turned and released.
- The tape keeper used in the GSI-2570 is heat treated spring steel, thus the tape keeper takes on the spring steel tension and retains its shape even if bent by trash falling down the tape carrier pipe. Other gauge models use non heat treated keepers, thus the keeper easily bends with trash falling down the tape carrier pipe. If the counter assembly actuation point is bent, it is compromised and loss of level accuracy occurs.
- The GSI-2570 uses self lubricating brass bushings in the tape storage sheave assembly and counter assembly housing. Others models use flattened out Teflon strips rolled as bushings to fit around the shafts. However, over time they will flatten out along the seam and bind.
- The GSI-2570's, Inch Dial Hub Assembly is all Stainless Steel and not Aluminum. The Inch Dial is pinned to the pinion operator gear, thus

no slippage during calibration.

- The GSI-2570 uses all 316 Stainless Steel fasteners, others use cadmium plated steel fasteners that when exposed to the elements, rust or bind.
- The GSI-2570 OPTIONALLY comes with an epoxy coating to reduce the amount of moisture entering the gauge head through normal breathing of the aluminum housing. It effectively seals the unit from water penetration.
- Retooling of the GSI-2570 mold in 1996 provided a heavier boss and some other minor physical improvements within the gauge head castings. Standardization in 1996 to 356 grade Aluminum has improved the quality of the gauge head and accessory castings.
- The GSI 2570 can be oil filled to reduce parts wear and the effect of product condensate and vapors entering the gauge. Oil fill plugs are provided on the counter housing and gauge housing. The use of condensation bottles when

### Theory of Operation

A hollow shell float is guided on a vertical plane by the use of either guide wires or a stilling well. Attached to the float is either a stainless steel tape or a tape/cable combination. The tape is manufactured with perforations precision measured over its length. As liquid is pumped into the tank the level rises, as liquid is pumped out the tank level falls. The movement of the level causes excess tape to be taken in (from the pulling of the Negator Motor Spring on the tape storage sheave assembly) or let out (from the weight of the float) from the tape storage sheave assembly. As the tape is pulled out or into the tape storage sheave assembly, the perforations in the tape match pins in the counter sprocket wheel. The counter sprocket wheel shaft is attached to the counter gauge dial which activates the counter assembly. As the tape runs over the sprocket wheel the counter assembly changes to reflect the identical change of tape movement across the counter sprocket wheel. Thus, the level is read.

oil filling a gauge is recommended, thus allowing water and trash to settle in the bottles and outside of the gauge head.

- OPTIONAL Condensation bottles with brass petcock valves for hand controlled moisture bleed-off of water in the gauge and counter housing are available.
- The GSI-SMT Scale and Moisture Trap OPTIONAL. Is used to prevent scale and moisture present in the tape guide piping from entering the gauge head, thereby reducing maintenance.
- The Hand Crank Assembly. The ratcheted hand crank replaces the normal gauge check handle and is a means of lifting the float from the product. It is used to allow the hoisting of the float during filling (low level product turbulence or air purging of lines back into tanks). In addition, the Crank Handle can be used to calibrate limit switch assemblies or supplied within gauge kits for dry bulk, Pelletized, or Granular Products that operate with a claw weight instead of a float.

### Gauge Head Configuration:

The GSI-2570 Mechanical Tank Gauge is offered in two standard configurations, the GSI-2570 "Plain Jane" and the GSI-2570 "Deluxe". The difference between the two basic configurations is that the "Deluxe" or DX Version includes the Negator Cassette Cartridge, the Dual Calibration Assembly, and Epoxy Paint Coating. The "Plain Jane" or PJ is only supplied with a standard Negator Motor Spring, standard Counter Assembly, and no finish on the Aluminum housing.

The GSI-2570 CS "Custom" gauge head is made to order with your choice of gauge head or kit options, i.e., material or kits with a non standard bill of materials (float changes, extra elbows or tape carriers, etc.)

Call Gauging Systems Inc. for assistance in configuring and ordering any custom gauges or gauge kits.

Other gauge head types offered include:

NC = PJ with Negator Cassette Only  
 DC = PJ with DCA Only  
 EC = PJ with Epoxy Coating Only  
 HP = PJ with Crank Handle  
 HD = DX with Crank Handle

### **Gauge Head Specifications:**

Accuracy:	1/8" or 3 mm
Range:	1/16" to 99', 1 mm to 30 M
Measurement:	Innage, Outage
Units of Measure:	English-Fractional, English-Decimal, or Metric
Material:	356 Aluminum cast body, Aluminum/Stainless trim, & Stainless Steel wetted parts.
Dimensions:	Height 14.08" Width 10.9" Depth 6.25"
Actuation:	Passive via 1/2" Stainless Steel perforated tape, 1" center to center perforations
Compatibility:	8" - 17" Guided Floats (Float weight 7 - 10 lbs.)
Connections:	Three 1-1/2" NPT (Top Center, Bottom Left, & Bottom Right) for tape carrier pipe. Two 3/8" NPT Drain Plugs One 3/8" NPT Counter Filler One 3/4" NPT Gauge Filler
Gauge Head Weight:	21 lbs.

*Specifications subject to change without notice.*

**GAUGING  
SYSTEMS  
INC**

**GSI-2570-DX Mechanical Tank Gauge**

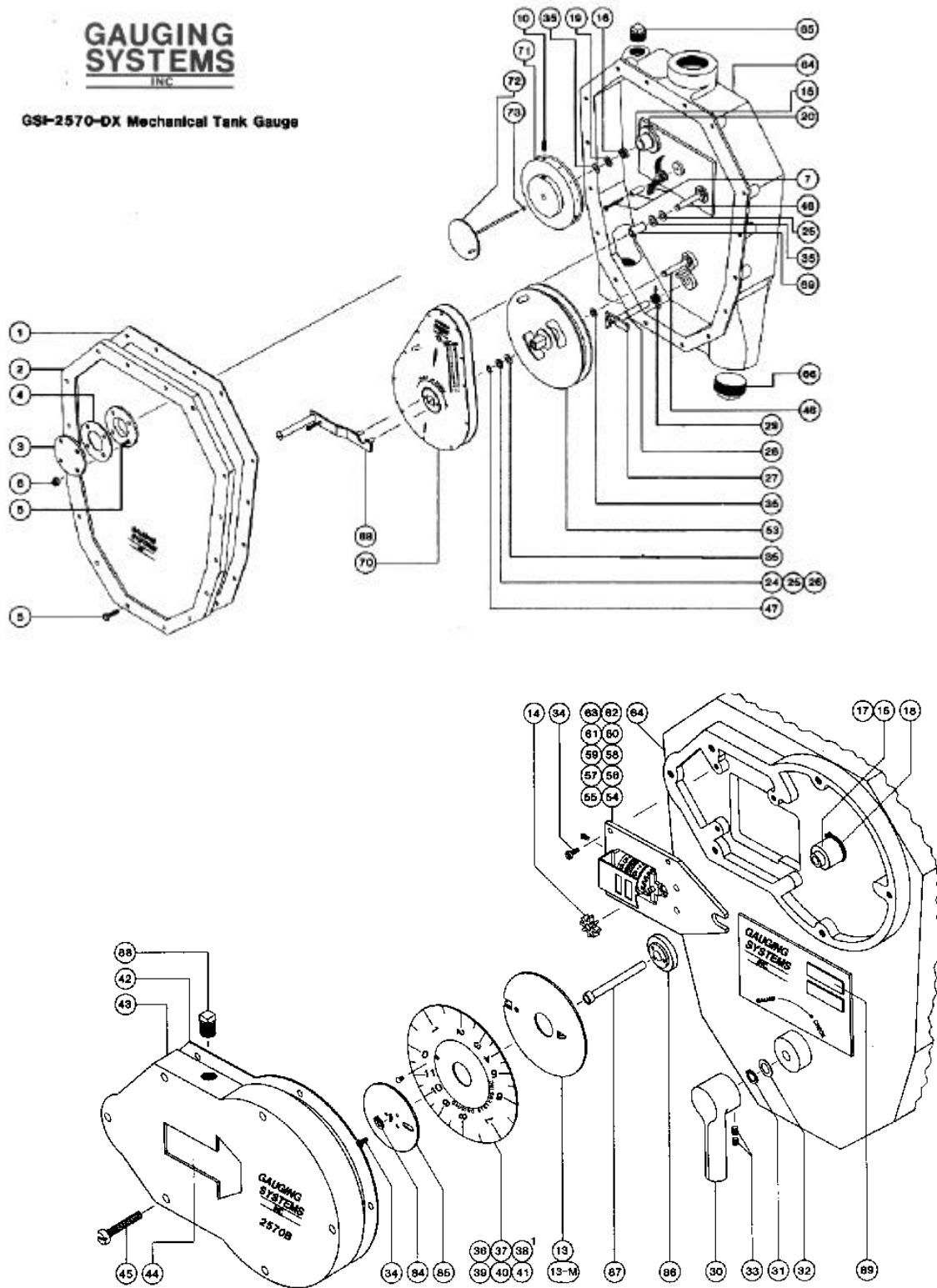

## GSI - 2570 Deluxe Gauge - Parts List

PART NO.	DESCRIPTION	FOOTNOTE (Parts included)
2570-Main-Kit	Maintenance Kit (Kit Includes Gaskets, Fasteners, and counter cover glass)	1, 4, 5, 7, 10, 19, 24, 25, 26, 34, 35, 42, 44, 47
2570-RB -Kit	Rebuild Kit (Kit Includes, Gaskets, Fasteners, Counter cover glass, Checker Assembly & Spring, Pinned Inch Dial, etc.)	1, 4, 5, 7, 10, 19, 16, 24, 25, 26, 27, 29, 35, 42, 44, 45, 47, 68, 69, & Pinned Inch Dial
2570-2	Back Cover	
2570-3	Back Cover Cap (B5060-001)	
2570-6	5/16-18 Elastic Stop Nut 4 ea.	
2570-7	Tape Keeper Assembly Kit	
2570-15	Gland Assembly Kit	15, 16, 17, 18, 19, 20, 24, 25
2570-27-Kit	Checker Assembly Kit	27, 28, 29, 30, 31, 32, 33
2570-36-PID	Inch Dial, English Innage (B8218-001)	13-IE
2570-37-PID	Inch Dial, English Outage (B9616-001)	13-OE
2570-38-PID	Inch Dial, Decimal Innage (B7987-001)	13-ID
2570-39-PID	Inch Dial, Decimal Outage	13-OD
2570-40-PID	Inch Dial, Metric Innage (B8325-001)	13-IM
2570-41-PID	Inch Dial, Metric Outage	13-OM
2570-43	Counter Cover	
2570-46	Sheave Assembly Shaft (BA7763)	
2570-53	TSSA for NC 2500B	
2570-54	Counter Assembly English Innage (BM18849-100)	14 & 34
2570-55	Counter Assembly English Outage (BM19954-100)	14 & 34
2570-56	Counter Assembly Decimal Innage (BM18849-100)	14 & 34
2570-57	Counter Assembly Decimal Outage (BM19954-100)	14 & 34
2570-58	Counter Assembly Metric Innage (BM18850-100)	14 & 34
2570-59	Counter Assembly Metric Outage	14 & 34
2570-60	Foot Wheel Innage x 1 (D6045-000)	
2570-61	Foot Wheel Innage x 10 (D6046-000)	
2570-62	Foot Wheel Outage x 1 (D6342-000)	
2570-63	Foot Wheel Outage x 10 (D6343-000)	
2570-64	Gauge Body	
GSI-DCA	Dual Calibration Assembly (English)	70, 72, 73, 84, 85, 86, 87
GSI-DCA-M	Dual Calibration Assembly (Metric)	70-M, 72, 73, 84, 85, 86, 87
GSI-NC Kit	Negator Cassette Kit (Deluxe Model Gauge Only)	

Contact GSI for a 2570 parts pad (for a complete parts list).

## Gauge Kits

Gauging Systems Inc. offers a variety of gauge kits to meet the tanks physical construction and/or the product service. Drawings of the gauge kits are on pages 7-9.

A gauge kit must first meet the physical mounting requirements of the tank, i.e., Cone roof, External floating roof, Internal floating roof, Cylinder tank, Sump, etc. Secondly, the gauge kit materials must be compatible with the product content of the tank. Thirdly, the proper gauge kit must be selected to meet the tank operation requirements or product needs.

Example: For agitated products with turbulent surface a cone dampener float or pan dampener float would eliminate the float from bouncing. This reduces wear and increases mechanical gauge and transmitter life. The reduction of float bounce will also reduce the number of nuisance (movement) alarms and allows the use of a marginal dead band when monitoring leak detection.

Example: For tanks that can't be taken out of service, GSI provides an In Service Kit. The kit consists of a weighted bottom anchor that can be lowered via the guide wires to the bottom of the tank, and an API 20" or 24" gauge hatch cover with top anchors and tape carrier pipe access built-in. In addition, the split design of the hatch cover allows an access opening into the tank to perform standard gauge maintenance.

Example: For tanks with an external metal dike, GSI provides the Universal Sheave Elbow for use as a tape carrier (every 10 feet) when spanning between the dike and the tank, thus preventing tape drag, i.e., lost actuation or possible gauge hang-up.

Example: For Internal Floating Roofs with Float Wells, GSI provides either guided floats or unguided floats with a wear ring as an option when ordering. GSI also gives the user the ability to select the float type and size provided with each kit.

Example: For heavy products, GSI uses inverted float clips on the guide wires that when placed in service are below the product level. Thus product doesn't dry on the float clips, reducing their size and possibly hanging the gauge. In addition, with heavy

products GSI uses a liquid seal. The liquid seal is filled with a compatible liquid to act as a cleaner, thus preventing vapors or product from being carried down the tape carrier pipe and into the gauge head.

For help on selecting the proper gauge kit configuration for your application, call Gauging Systems Inc. Our support staff is always ready to provide feedback or suggestions.

### **Gauge Kit Specifications:**

#### Materials Available:

Punched Tape	316 SS Monel
Cable	316 SS Monel Teflon Coated
Guide Wire 1/8"	316
Bottom Anchor	Carbon Steel 304/316 SS
Top Anchors	304/316 SS Internals
	Carbon Steel 304/316 SS Housing
Sheave Elbows 90°, Liquid Seal, and Universal.	UHMW 304/316 SS Rollers
	Aluminum Housing

#### Gauge Kit Weight:

Gauge kits vary in weight by configuration and tank height.  
Minimum weight 50 lbs.  
Maximum weight 115 lbs.

*Specifications subject to change without notice.*

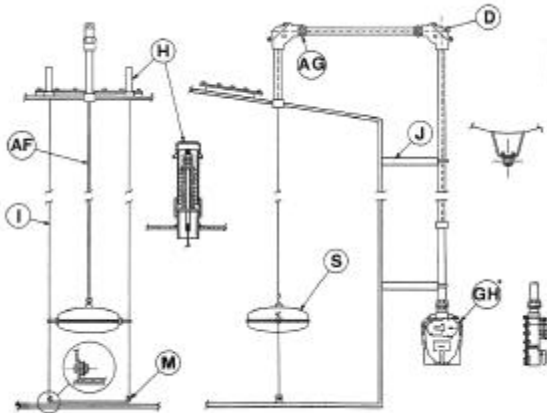

**GSI-2570 Kit**  
Cone Roof, Ground Reading

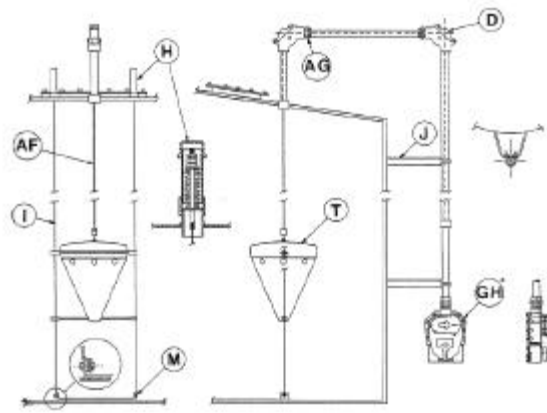

**GSI-2570-TURB Kit**  
Turbulent/Agitated Product, Ground Reading

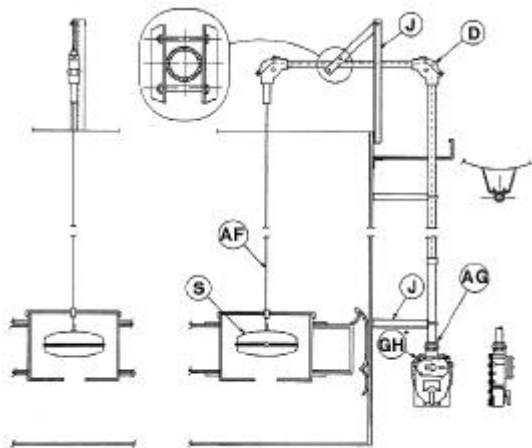

**GSI-2571 Kit**  
External Floating Roof with Float Well

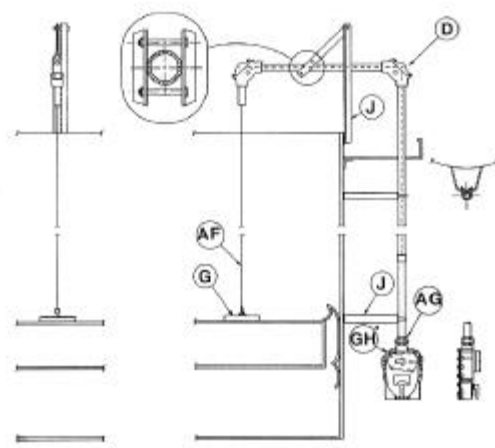

**GSI-2572 Kit**  
External Floating Roof without Float Well

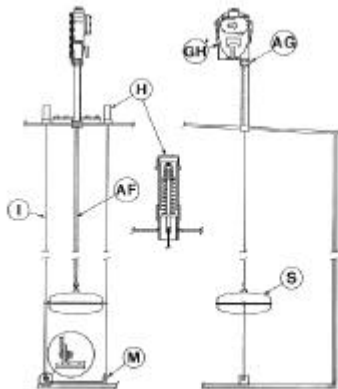

**GSI-2573 Kit**  
Cone Roof Tank, Top Mounted

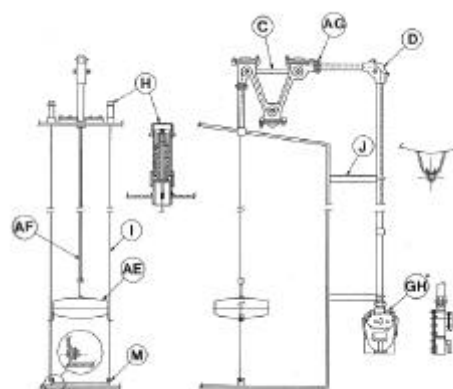

**GSI-2574 Kit**  
Cone Roof Tank with Liquid Seal



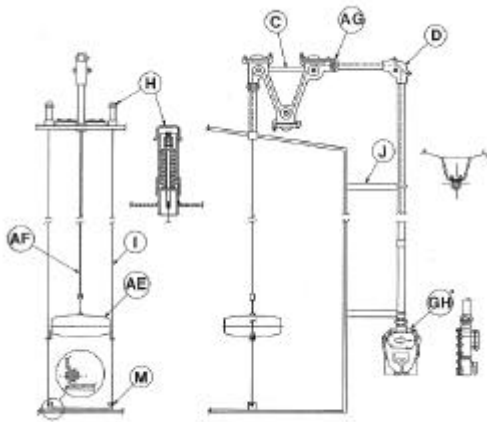

**GSI-2574-HVPD Kit**  
Heavy Products Tank with Liquid Seal

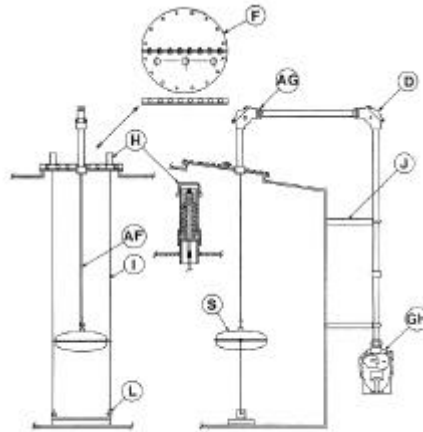

**GSI-2575 Kit**  
In Service Kit for Cone Roof Tank

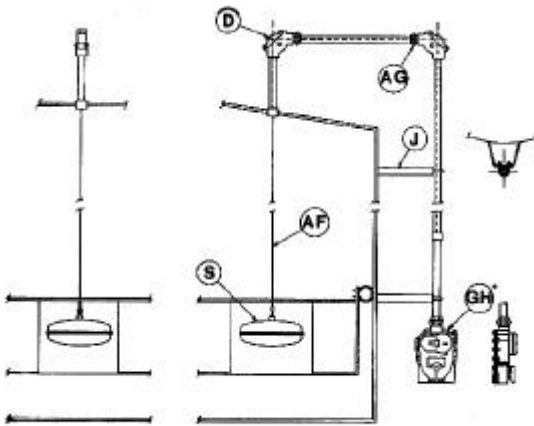

**GSI-2576 Kit**  
Internal Floating Roof with Float Well

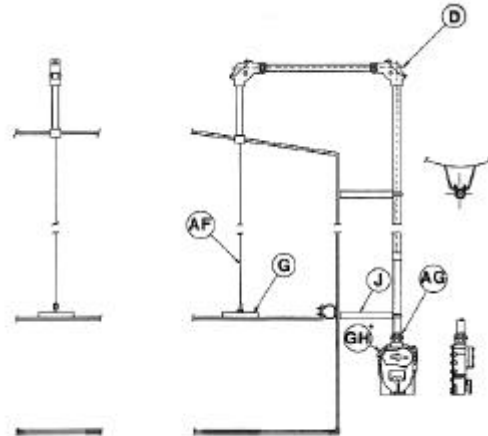

**GSI-2577 Kit**  
Internal Floating Roof without Float Well

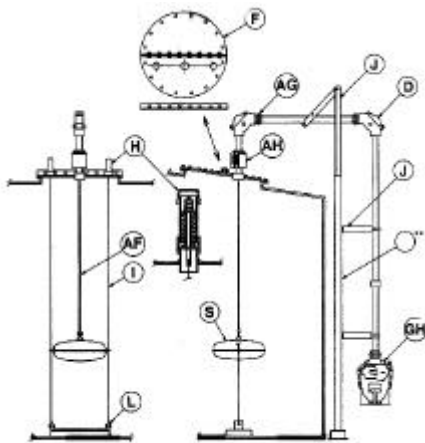

**GSI-2578-HACC Kit**  
High Accuracy in Service Kit, Cone Roof

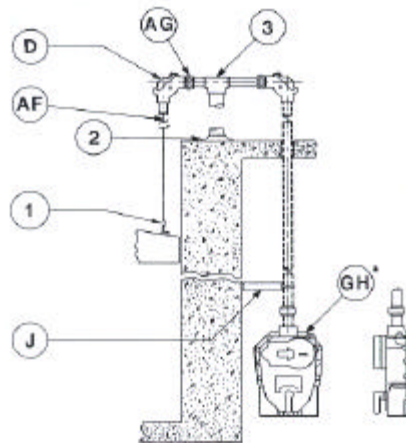

**GSI-2579 Kit**  
Digester Cover Position Indicator



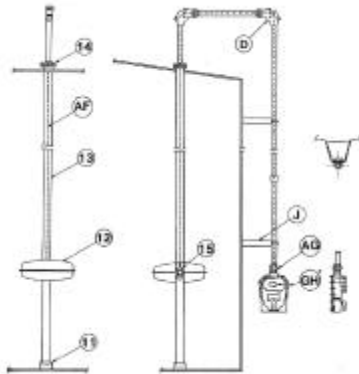

**GSI-2580  
Magnetic  
Gauge  
Kit  
(Closed  
vapors)**

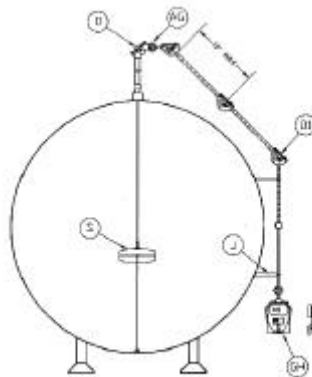

**GSI-2581  
Cylinder Tank  
Mounting Kit,  
Ground  
Reading  
(Low Pressure)**

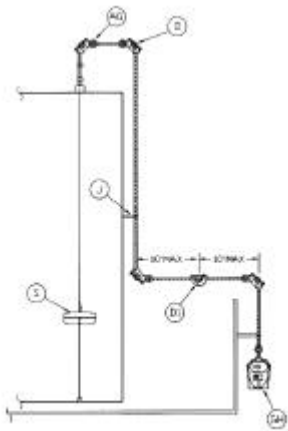

**GSI-2582  
External Tank  
Dike Ground  
Reading Kit**

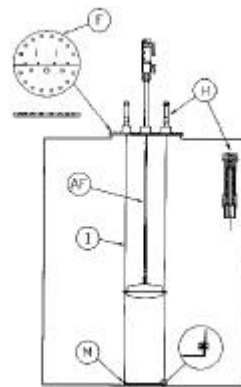

**GSI-2583SK  
In Service Kit  
Top Mounted  
(Sump Kit)**

## GSI Tank Gauging Parts and Accessories

Ref.	Part Number	Description
A	GA-H0XX	Inspection Cover, Carbon Steel, Bolted or Welded
B	GSI-277X	Valve, Tape/Cable Block
C	GSI-SE180	Liquid Seal, Aluminum, SS Fasteners, UHMD Rollers (SS Optional)
D	GSI-SE90	Sheave Elbow 90°, Aluminum, SS Fasteners, UHMD Rollers (SS Optional)
D1	GSI-USE	Universal Sheave Elbow (Can be used as a tape carrier, 45°, 90°, or Drive Elbow), Aluminum, SS Fasteners, UHMD Rollers (SS Optional)
Optional)		
E	GA-SE-XXX	Sheave Roller Replacement Kit or Yoke & Lanyard Kit
F	GA-H003	Manhole cover, API 24" Diameter, Bolted, Carbon Steel
G	GA-RW01	Roof Weight with cable connector, 7 lbs., Stainless Steel
H	GA-AT01	Top Anchor, 1-1/4" NPT, CS Housing, SS Internals
I1	GA-GW-1/8	Guide Wire, Single 1/8" Diameter, Stainless Steel
J1	GA-BR01	Side Mounting Bracket, Carbon Steel with SS U-bolt
J2	GA-BR02	Top Mounting Bracket, Carbon Steel with SS U-bolt
K	GSI-SMT	Scale & Moisture Trap, Aluminum with Brass Petcock
L	GA-ABW1-XX	Bottom Anchor, Weighted, 50 lbs., Two Guides, 13" or 17" Diameter, CS
M	GA-AB04-XX	Bottom Anchor, Two Guides, 13" or 17" Diameter, CS
N & O	GA-CB-XXXXX	Condensation Bottles, Gauge Body & Counter Cover
P	GA-FL-CLIP	Float, Guide Clip SS
Q	GA-T-CLAMP	Tape Clamp, SS
R	GSI-NCXXXX	Negator Cassette
S1	FL-17-HS-G	Float, 17" Diameter, Hollow Shell, Guided, SS
S2	FL-15-HS-U	Float, 15" Diameter, Hollow Shell, Non Guided, SS
T	FL-17-HS-CD	Float, 17" Diameter, Hollow Shell, Cone Dampener, Guided, SS

**GSI Tank Gauging Parts and Accessories Continued**

V	GA-FL SNAP	Float, Snap Type Fastener, SS
W	GA-FL-BOLT	Float, Bolt Snap Swivel Connector, SS
X	GSI-DCA	Dual Calibration Assembly
Z	FL-12-B-WR	Float, 12" Diameter, Ball with Wear Ring, SS (Stilling Well applications)
AB	GA-FL-SWVL	Float, Swivel (Long or Short), SS
AC	GSI-CRANK	Crank Handle Assembly Kit (Optional for all gauge kits)
AE	FL-17-HS-IC	Float, 17" Diameter, Hollow Shell, Inverted Clips, SS
AF	TAPE-T-1-XX	"TUFF" Tape, 1" Perforations, 1/2" Width x XX Length, SS
AF	TAPE-C-1-XX	Tape/Cable Combination, 1" Perforations, 1/2" Width x XX Length, SS
AG	GA-BR-UNION	OPTIONAL - Pipe Union, 1-1/2" NPT, CS
AH	GA-XJT	Expansion Joint, 1-1/2" NPT, 3" Diameter, Aluminum, Buna Seal
GH	GSI-2570	Gauge Head, Aluminum (DX - Deluxe, PJ - Plain Jane, or CS - Custom)
1	GA-BR-DG1	Digester Cover, Cable Attachment Bracket
2	GA-BR-DG2	Digester Cover, Pipe Support Mounting Flange

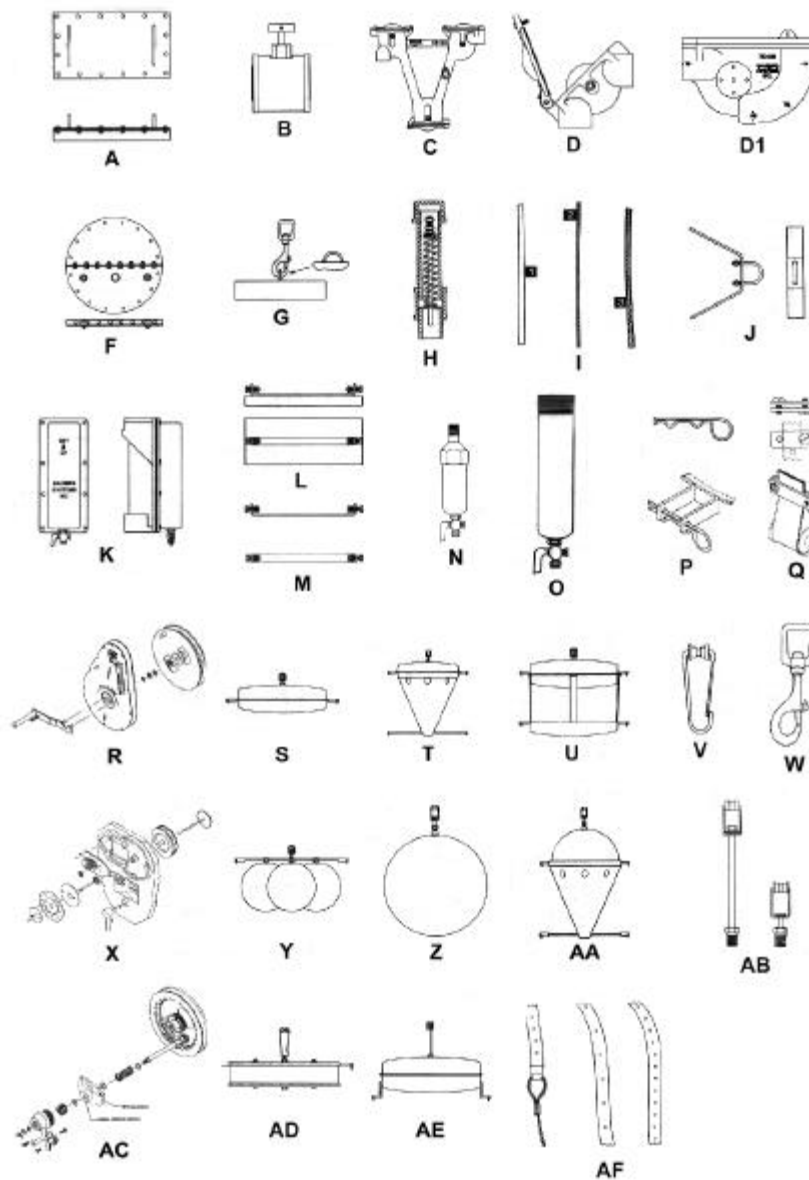

## Gauge Kit Accessories

Gauging Systems Inc. manufactures a variety of tank gauge accessories designed to improve tank gauge performance, provide ease of installation, and reduce maintenance of both new gauge installations and the retrofit of older gauge installations. The accessories are sized to retrofit most manufacturers' gauges or gauge kits installed over the last 40 years. Variations between gauge manufacturers will most likely be found in the float diameter and weight, the bottom anchor width, and the spacing and diameter of the punched tape. GSI supports these variations between different manufacturers with parts in stock and on the shelf. See the Gauge Parts and Accessories diagram on Page 10.

Accessories such as condensation bottles for the GSI 2570 are recommended. The condensation bottle (transformer oil filled or not) eliminates any vapors (moisture) due to condensation from product temperature change from settling within the gauge head. Corrosion of parts and the binding of the gauge could otherwise occur.

Hollow shell floats are recommended over foam glass filled floats. The latter can cause variations in measurement between the mechanical gauge and hand lined measurements due to the draining of product from the float when the gauge is checked. Thus the float is lighter and resting on top of product when calibrated vs. 10 minutes later when product has absorbed back into the float, adding weight, and settling deeper into product.

The GSI SE 90 Sheave Elbow uses a hinged lid with all captive fasteners. Thus, there are no parts to climb down the tank to pick up... The GSI Universal Sheave Elbow can be machined and ordered as a 45° Elbow, 90° Elbow, Tape Carrier, Drive Elbow, or all of the options listed (spare part for emergencies).

Contact Gauging Systems Inc. for a Gauge Parts and Accessories Pad. The Pad fully lists all accessory items available through GSI.

## GSI – 2570 Gauge and Gauge Kit Ordering Information

**Model Number Specification: GSI – A – B – C – D – E**

**A = Gauge Head or Gauge Kit**

- 2570GH= Gauge Head Only**
- 2570 = Cone Roof, Ground Reading**
- 2570TR = Turbulent/Agitated Product, Ground Reading**
- 2571 = External Floating Roof with Float Well**
- 2572 = External Floating Roof without Float Well**
- 2573 = Cone Roof, Top Mounted**
- 2574 = Cone Roof, Ground Reading with Liquid Seal**
- 2574HV = Heavy Products Kit, Ground Reading with Liquid Seal**
- 2575 = Cone Roof, Ground Reading with In Service Kit**
- 2576 = Internal Floating Roof, Ground Reading with Float Well**
- 2577 = Internal Floating Roof, Ground Reading without Float Well**
- 2578 = Cone Roof, Ground Reading, High Accuracy in Service Kit**
- 2579 = Digester Cover Position Indicator**
- 2580 = Magnetic Gauge Kit, Ground Reading**
- 2581 = Cylinder Tank, Ground Reading**
- 2582 = External Tank Dike, Ground Reading**
- 2583 = Sump Kit, Top Mounted with In Service Kit**

## GSI – 2570 Gauge and Gauge Kit Ordering Information Continued

### B = Gauge Type

- PJ = Plain Jane Gauge (Standard)
- DX = Deluxe Gauge (Epoxy coated, Negator Cassette, Dual Calibration Assembly)
- CS = Custom Built Gauge (Specify all required options, i.e., materials, etc.)
- NC = PJ with Negator Cassette Only
- DC = PJ with Dual Calibration Assembly Only
- EC = PJ with Epoxy Coating Only
- HP = PJ with Crank Handle
- HD = DX with Crank Handle

C = Tank Shell Height (Indicate F for Feet and M for Meters, Example 15M = 15 Meters)

### D = Gauge Reading and Unit of Measure

- IE = Innage, English-Fractional (Standard)
- ID = Innage, English-Decimal
- IM = Innage, Metric
- OE = Outage, English-Fractional
- OD = Outage, English-Decimal
- OM = Outage, Metric

### E = Float Size / Guides, Center to Center (If applicable to the gauge kit being ordered)

- 17 = 17" Center to Center, Guided, Hollow Shell Float (Standard)
- 15 = 15" Unguided Hollow Shell Float with Wear Ring
- 13 = 13" Center to Center, Guided, Hollow Shell Float
- 11 = 11" Unguided Hollow Shell Float with Wear Ring
- 10 = 10" Ball Float with Wear Ring (Stilling Well Application)
- 8 = 8" Ball Float with Wear Ring
- 00 = Other (Specify Float Requirements, See GSI Float Bulletin 2605)

#### Gauge Kit Example:

Model Number: 2571-DX-42F-IE-15

- 2571 = External Floating Roof with Float Well
- DX = Deluxe Gauge Head
- 42F = Tank Height 42 Feet
- IE = Innage, English-Fractional Measure
- 15 = 15" Unguided Float with Wear Ring

**If you have any questions, call, fax, or e-mail Gauging Systems Inc.**