

# DREXELBROOK<sup>®</sup>

## Safety IntelliPoint for Floating Roof Tanks

### Overfill Prevention



### Specifically designed for Floating Roof Tanks (Internal and External roofs) with Flexible Sensing Element 700-0005-595

- Field Adjustable lengths from 1' to 15' (0.3 to 4.57 m) 12" to 180" (305mm to 4572 mm)
- Wetted Parts: 316SS 1-1/2" NPT Mounting, 3/16" FEP insulated flexible and adjustable cable, Non-Sparking Brass Sensor.

### Features:

- 2 Wire or Line Powered
- Alarm trip points with any contact of internal or external roof.
- Alarm trip points in "Sunken Roof" applications with less than 1" product.
- One system will fit most floating roof tank application needs, reducing field spares.

### Intelligent Electronics

- Meets API 2350 regulations.
- For use in safety related systems with requirements for functional safety for SIL2 (SIL 3 with Redundant Switch) In accordance to IEC61508-2, ed2, 2010 (EXIDA)

- No calibration or setpoint adjustments.
- Automatically recognizes and ignores coatings to prevent false alarms.
- Continuous Self-Test monitors circuits and sensing elements for faults

### Dual Compartment Housing

The dual compartment housing separates the customer wiring from the sensing element and operating circuits. The encapsulated power supply/ terminal block design eliminates the possibility of damage caused by moisture in the conduit.

### Self-Test Feature

Automatic and Local or Remote Manual test functions ensure proper system operation.

### Auto Verify™

Each IntelliPoint™ is supplied with a continuous self-test feature that constantly monitors the integrity of not just the electronics, but the sensing element and interconnecting cable. If a fault is detected, the IntelliPoint Auto Verify™ feature alerts plant personnel.

### Manual Certify™

The IntelliPoint™ provides a method to manually test the entire system without removing the sensor from the tank. The Manual Certify Test checks that the Auto Verify circuits are operating and confirms the probe and cables are properly connected. The Manual Certify also allows the IntelliPoint™ electronics to sense changes in the probe that simulate contact with the media or a floating roof. This provides the user with a method to insure working performance without having to climb the tank. At the completion of the Certify test routine, the output is momentarily held in the alarm state so personnel can confirm that the control circuits connected to the Final Control Element are functioning properly.

# Floating Roof Tanks

## Specifications

**Technology:** RF Admittance/Capacitance

**Calibration:** None

**Modes Of Operation:** High Level Fail Safe

**Repeatability:** 2 mm (0.08 inch) conductive liquids

**Response Time:** Less than one second

**Indicators:** LEDs: Green Power, Red Alarm

### Self-Check:

AutoVerify automatically and continuously checks electronics and sensing element for faults. Manual Certify checks that the AutoVerify circuits are functioning.

**Time Delay:** 0-60 seconds, forward acting

### 2 Wire Loop Powered:

**Power Supply:** 13 to 30 VDC

Note: The minimum supply voltage at the transmitter terminal is:

13 VDC at 22mA (Fault)

19 VDC at 5mA (Fault)

**Power Consumption:** 1 Watt maximum

**Output:** (or field-selectable)

8 mA - Alarm

8 mA - Normal

16 mA - Normal

16 mA - Alarm

22 mA - Fault

5 mA - Fault

### Line Powered:

**Power Supply:** Universal Supply

85 to 250 VAC

21 to 100 VDC Auto-Detecting w/o Jumper Changes  
DC to 400 Hz

**Power Consumption:** 2 Watts maximum

**Relay Contacts:** (2) SPDT

Maximum Contact Load:

5A/30 VDC/ 5A/250 VAC - Environmentally Sealed

Minimum Contact Load (DC):

100 mA/12 VDC

0 to 200 mA / 12 VDC Optional

### Ambient Electronic Temperature:

-30 to 58°C (-22 to 136°F) IECEx Line Powered

-30 to 70°C (-22 to 158°F) ATEX / IECEx 2 Wire

-40 to 70°C (-40 to 158°F) FM / FMC

### Storage Temperature:

-40 to 85°C (-40 to 185°F)

**Housing:** Dual Compartment, Powder-Coated aluminum with two cable entries

### Cable Entry:

M20 x 1.5 (ATEX / IECEx)

¾-inch NPT (FM / FMC)

**Ingress Protection:** IP66 NEMA 4, 4X

### Approvals:



The IntelliPoint RF Point Level System Transmitter has been evaluated as Explosion-proof for use in Class I, Division 1, Groups A, B, C, and D, Dust-Ignition proof for use in Class II and III, Division 1, Groups E, F, and G; Non-incendive for use in Class I, Division 2, Groups A, B, C, and D;

Suitable for use in Class II and III, Division 2, Groups F and G Hazardous (Classified) Indoor and Outdoor (Type 4, 4X, IP66)

Locations with Intrinsically Safe connections to Class I, II, and III, Division 1, Groups A, B, C, D, E, F, and G Hazardous (Classified) locations.

Reference control drawing 420-0004-144-CD for the SxRxL Series and Control Drawing 420-0004-173-CD for the SxRxT Series; Intrinsically Safe for use in Class I, II, and III, Division 1, Groups A, B, C, D, E, F, and G hazardous (Classified) locations in accordance with entity requirements and control drawing 420-0004-173-CD.

### ATEX: (FM14ATEX0049)

2 Wire Loop Powered

II 1 G Ex ia IIC T5...T2 -30°C ≤ TAMB ≤ +70°C; IP66

II 1 D Ex ia IIIC T90°C -30°C ≤ TAMB ≤ +70°C; IP66



Reference control drawing 420-0004-175-CD for SxRxT entity and installation requirements

### IECEX: (FTZU 18.0007X)

2 Wire Loop Powered

Ex ia IIC T5 Ga

Ex ia IIIC T90°C Da

-30°C ≤ Ta ≤ 70°C

Reference control drawing 420-0004-562-CD for SxRxT entity and installation requirements



### MTTF (Mean Time to Failure):

285 Years, Independently Tested

### Safety:



SIL2 (SIL 3 with Redundant Switch)

IEC61508-2 ed2, 2010 (EXIDA)

**Dimensions**

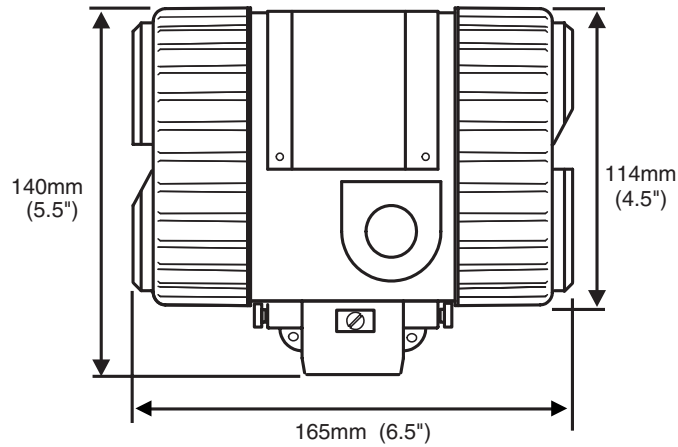

**Input Wiring**

**2 Wire Loop**

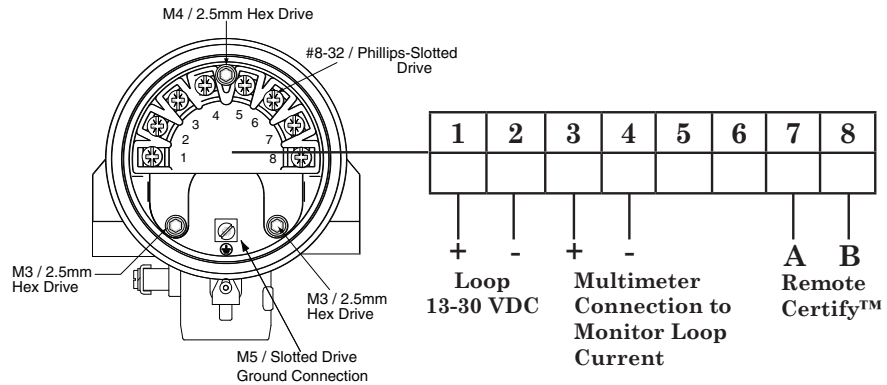

**Line Powered**

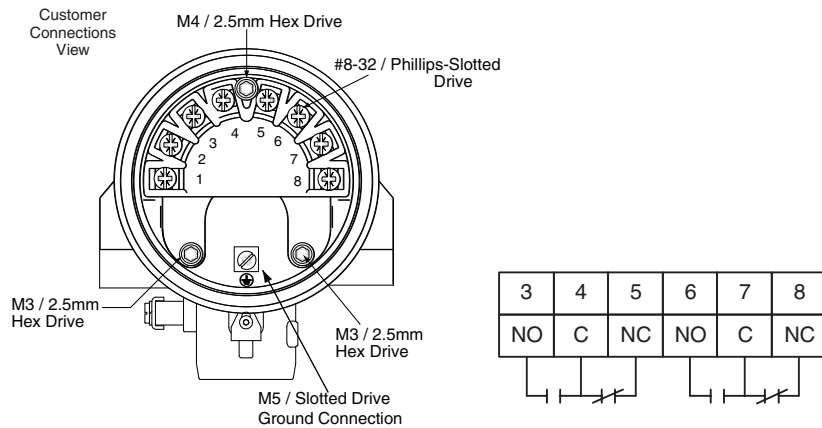

# Floating Roof Tanks

## Sensing Element for Floating Roof Tanks 700-005-595

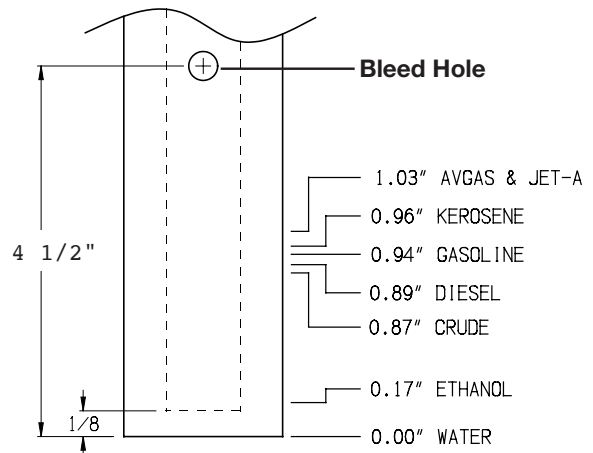
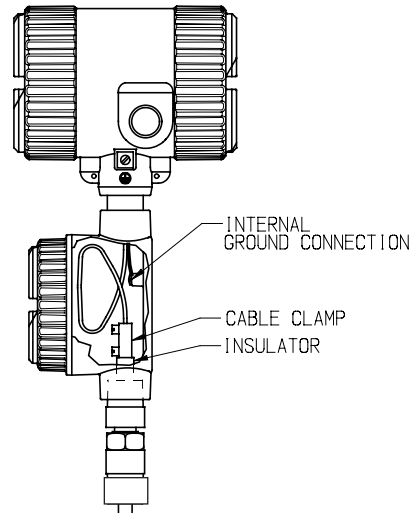
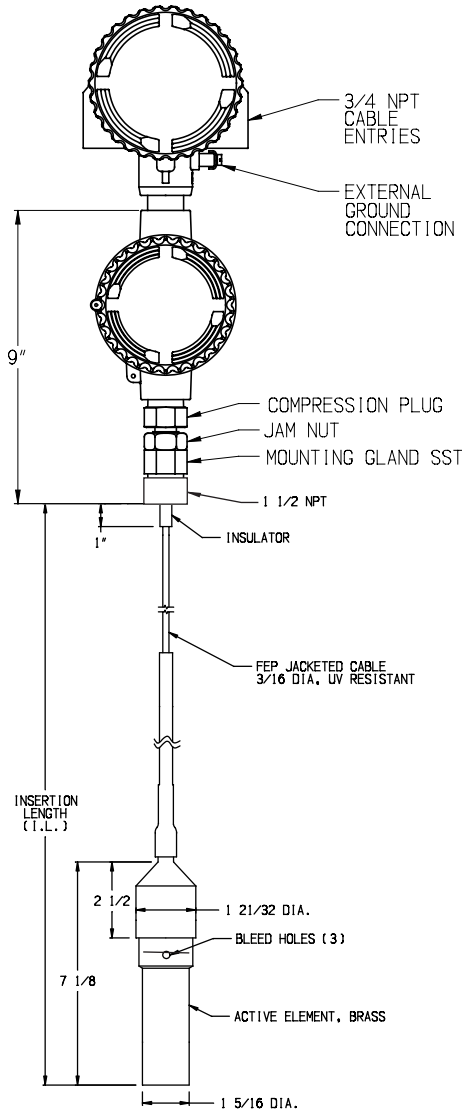

### Alarm Trip Points

- Tip Sensitive on metal roofs and conductive liquids

# Floating Roof Tanks

## Model Numbering

